



Top-Flo[®] Hygienic Diaphragm Valves



Engineered Valve Solutions for
High Purity Industries

www.toplineonline.com

TOP-FLO[®] Hygienic Diaphragm Valves

“Our Name Says It All”



Top Line Process Equipment Company is well known for providing its customers with products that will meet or exceed the quality standards found in the many markets we serve. **Top Line** competes with the major suppliers in the industry in North and South America for weir type diaphragm valves and we have recently gained approval to mark CE on our valves in accordance to the PED on this product line. Pricing is very competitive and our lead times are typically outstanding compared to our competition.

Top-Flo[®] diaphragm valves, because of their unique design, reliability, versatility, and ease of maintenance have been the ideal choice for high purity process piping applications. We combine world class industry experience with engineering and manufacturing facilities located in the USA and Canada. Our R&D, engineering, and manufacturing groups are committed to providing high quality valves that are unsurpassed by any of our competitors.

Here are some key standard features to consider for your next requirement:

- Low ferrite DIN 1.4435 316L forged body sizes 1/4”-4” with controlled sulfur content to ASME BPE 0.005-0.017 with 3.1B Material Certification
- Autoclaveable Viton[®] o-ring sealed 304SS stainless steel manual bonnet with adjustable PPS thermoplastic handwheel
- Thermoplastic piston type pneumatic actuators with your choice of popular controls for feedback (Westlock, Stonel, Burkert, etc.)
- FDA and USP Class VI (Sections 87 & 88) conforming steam grade EPDM, TFM/EPDM, and TFM/Viton[®] backed diaphragms
- Specialty fabricated sterile access and GMP style valves
- Zero DL machined block body style valve types - Point of Use, T-pattern, Divert style, Tank Bottom, and many others specialties as designed
- Interchangeable diaphragms and topworks with most other manufacturers
- Extensive on the shelf inventory for project support

Top Line’s name adds essential value, including specification assistance, outstanding delivery performance, and on-site technical support. All of these benefits allow Top Line to offer a wide range of products and services designed specifically to meet your every requirement.

Table of Contents

Bio-Pro [®] Forged	1
Bio-Pro [®] Cast	2
Bio-Flo II [®]	3
Specialty Valve Assemblies	4-6
Divert Valve	7
Actuation.	8-11
Bonnet Assemblies	12
Diaphragms.	13
Electropolishing.	14-15

Bio-Pro® Forged

The forged body has always been the optimum choice for applications within the bioprocessing and pharmaceutical industries.

Bio-Pro® forged body diaphragm valves will be the valves of choice when high purity mechanical and electropolished surface finishes are required.

Bio-Pro® forged bodies are manufactured from ASTM A182 GR F316L material with additional controls in regards to chemical content. The sulfur content is maintained to meet and exceed the stringent requirements of BPE. All forgings are solution annealed to maintain the ferrite content to be .05% or less. This low ferrite content eliminates the concern for contaminants and migration of oxides throughout the system. Machining of the contours are performed by using state of the art cad/cam system assuring repeatability of the weir and valve cavity profiles for full drainability. Each forging contains two hash marks clearly indicating the drain angle plane for ease of installation.

Bio-Pro® forged bodies are in compliance with FDA guidelines as well as cGMP principles, and are specifically designed for use in ultra pure applications where sterility is critical. **Top Line** provides these bodies with heat numbers etched into them for full traceability. Mill test summaries are provided with each shipment.

Bio-Pro® forged diaphragm valves are available in sizes ranging from 1/2" through 6" with clamp or weld end connections and surface finishes ranging through 10 RA. **Top Line** can also manufacture valves in AL6XN, Titanium, Hastelloy C, or other alloys if required.

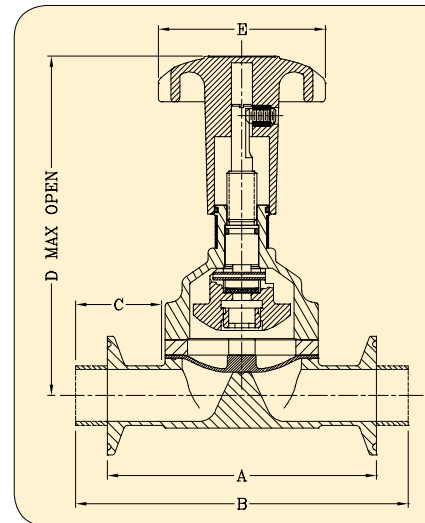

STANDARD END CONNECTIONS	
14-16-18 Gauge O.D. Tube	Tube end style valves have 0.75" Minimum tangent length to facilitate orbital welding
OPTIONAL END CONNECTIONS	
Schedule 5,10,40	Various clamp type connections including ISO 2852 (BS 4825-Part 3)
ISO 1127	Hygienic screwed connections inclusive of BS 1864, SMS, DIN 11851, ISO 2853, (BS4825-Part 4)
DIN 11850	
SMS 3008	

Bio-Pro® Forged Manual Valve Dimensions

Size	A Clamp End	B Od Tube End	C Weld Tangent	D Center To Top	E Handwheel	F Drain Angle
1/2"	3.50	4.88	1.50	4.47	3.00	30°
3/4"	4.00	5.31	1.50	5.00	3.00	25°
1"	4.50	5.56	1.50	5.69	3.00	28°
1 1/2"	5.50	6.63	1.50	8.47	4.75	20°
2"	6.25	7.50	1.63	9.88	4.75	20°
2 1/2"	7.63	10.00	1.88	8.82	8.00	18°
3"	8.75	10.00	1.88	10.00	8.00	20°
4"	11.50	12.84	2.00	13.63	10.00	15°
6"*	13.40	18.00	3.00	18.00	16.00	15°

* MACHINED FROM 316L BAR

Bio-Pro[®] Cast



Bio-Pro[®] cast valves offer an economical alternative for less demanding service applications in food, dairy, beverage, pharmaceutical, cosmetic, personal care and bio-tech markets.

Bio-Pro[®] cast bodies are low carbon stainless steel investment castings that conform to ASTM A351 grade CF3M (316L) material. Castings are solution annealed to provide a sanitary and clean outside finish. Available in sizes 1 1/2" through 6" with either clamp or butt weld end connections.

Bio-Pro[®] cast bodies are available with a variety of surface finishes ranging from 20Ra to 35Ra including electropolish. Hash marks are provided on each body to optimize drainability and facilitate installation. Heat numbers are marked on the bodies to provide full traceability with material test summaries being furnished with each order.

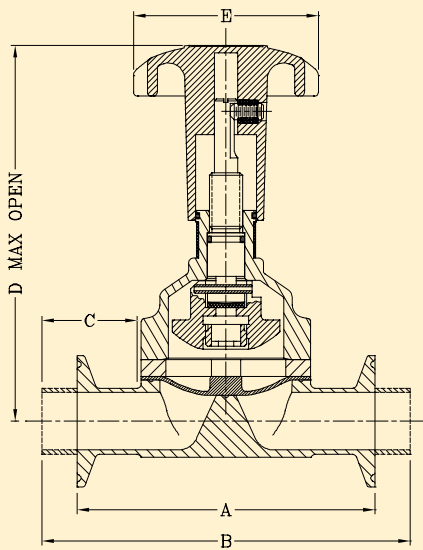

STANDARD END CONNECTIONS

14-16-18 Gauge O.D. Tube	Tube end style valves have 0.75" Minimum tangent length to facilitate orbital welding
--------------------------	---

OPTIONAL END CONNECTIONS

Schedule 5,10,40	Various clamp type connections including ISO 2852 (BS 4825-Part 3)
ISO 1127 DIN 11850 SMS 3008	Hygienic screwed connections inclusive of BS 1864, SMS, DIN 11851, ISO 2853, (BS4825-Part 4)

Bio-Pro[®] Manual Valve Cast Dimensions

Size	A Clamp End	B Od Tube End	C Weld Tangent	D Center To Top	E Handwheel	F Drain Angle
1/2"						See Forged Valves
3/4"						See Forged Valves
1"						See Forged Valves
1 1/2"	5.50	6.25	1.31	8.47	4.75	20°
2"	6.25	7.50	1.59	9.88	4.75	20°
2 1/2"						See Forged Valves
3"	8.75	10.00	1.75	10.00	8.00	20°
4"	11.50	12.50	1.63	13.63	10.00	15°
6"						See Forged Valves

Bio-Flo® II

Bio-Flo® II diaphragm valves are compact, forged, and lightweight valves designed to meet the stringent requirements within high purity systems. Applications include sampling, drain ports, steam ports, and specialty fabrications.

Bio-Flo® II valve bodies are manufactured from the same forged 316L material as the standard Bio-Pro® forged bodies. All **Bio-Flo® II** valve sizes are machined from a common raw forging with controlled chemistry per ASME BPE. Bodies are available with clamp or buttweld ends and surface finishes through 10RA.

Bio-Flo® II manual 304 stainless steel bonnets are provided with adjustable PPS handwheel, sanitary internals, and Viton® o-ring seal. Bonnets are autoclavable and can withstand elevated temperatures to 300° F.

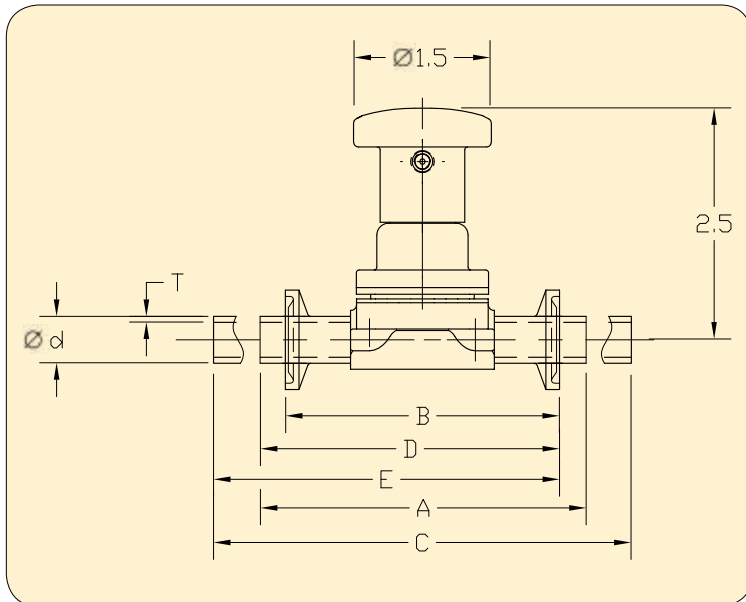

STANDARD END CONNECTIONS

16-18-20 Gauge
O.D. Tube

Tube end style valves have 0.75"
Minimum tangent length to
facilitate orbital welding

A = Standard Butt Weld

B = Standard Clamp

C = Extended Butt Weld*

D = Standard Clamp X Butt Weld

E = Standard Clamp X Extended Butt Weld*

*per ASME BPE

Bio-Flo® II Dimensions

Size	DN	ØD	T	A	B	C	D	E
1/4"	8	0.250	0.035	3.06	2.563	3.89	2.81	3.23
3/8"	10	0.375	0.035	3.06	2.563	3.89	2.81	3.23
1/2"	15	0.500	0.065	3.06	2.563	3.89	2.81	3.23

All dimensions are in inches unless otherwise noted.

Specialty Valve Assemblies

Top Line for years has specialized in manufacturing custom fabricated products designed specifically to meet our customers' requirements.

Our primary objective has always been to design and manufacture these specialty products by using state-of-the-art manufacturing practices and technologies.

Top Line and its affiliates employ engineers with a vast range of expertise and knowledge in the bioprocessing and pharmaceutical industries. The benefit of this is our ability to provide quick and accurate solutions to even the most complicated problems that occur in the field.

All specialty products are manufactured using good manufacturing practices and are put through a very rigid quality control inspection before leaving our facility. These practices ensure that our customers receive quality parts ready for immediate installation.

In addition to the standard 2-way valve bodies, **Top-Flo®** diaphragm valves offer various configurations and assembly types.

- Tank Bottom
- T-Pattern
- L-Pattern Valves
- Access Valves
- Point-of-Use Valves

L-Pattern Type

The L-pattern type diaphragm valve, due to its unique design, minimizes deadlegs in point-of-use outlets. The valve, while installed in a vertical position, serves as a 90-degree elbow. As fluid passes through the body, the valve can be opened to allow provision of uncontaminated samples. The outlet can also serve as a drain or a divert port.



Manufactured from forged 316L stainless steel in sizes ranging from 1/4" through 6", the L-pattern type can be supplied with buttweld or clamp end connections and a wide variety of finish options.

Zero DL™ T-Pattern

T-pattern type valves improve drainability and greatly eliminate deadleg. Typically installed in a horizontal position, this valve also provides for excellent sampling or diverting of critical process fluids throughout the process system.

Zero DL™ T-pattern valves are available in sizes ranging from 1/4" through 6". These valves are machined from a solid block of 316L stainless steel with T characteristics through 6". A wide variety of end connections and surface finishes are offered to meet your specifications.

- Integral sample valves available upon request.



Zero DL™ Tank Bottom Diaphragm Valves

When bacteria entrapment or leaking gland seals associated with other types of valves problems in the system, the Zero DL™ tank bottom valve is a reliable solution that can be used to eliminate such concerns.

The Zero DL™ tank bottom valve, with its conical profile allows for complete drainability and the prevention of deadlegs or entrapment areas. These valves are installed by either bolting or welding to the tank surface.

Zero DL™ tank bottom valves are available in sizes ranging from 1/4" through 4", are manufactured using type SA-479 316L stainless steel and are available with a wide variety of drain ports and end connections. Positive closure can be achieved by means of manual or pneumatic actuation.

Top Line offers many surface finish options to meet your specifications. In addition, heat numbers are etched into the body providing full traceability with mill test summaries provided.

- 30° outlet - standard
- 45° outlet - upon request



Specialty Valve Data

Zero DL™ T-Pattern Dimensions

Size	A		B		C		D		E		F		
	INCHES	MM	INCHES	MM	INCHES	MM	INCHES	MM	INCHES	MM	INCHES	MM	
1/2	15	2-3/4	70	2-3/8	60	3-1/2	89	3	76	4-1/4	108	3-1/2	89
3/4	20	3	76	2-11/16	68	3-3/4	95	3	76	4-5/8	118	4	102
1	25	3-3/8	86	3-1/8	79	4-5/16	110	3	76	5	127	4-1/2	114
1-1/2	40	4-1/4	108	3-7/8	198	6-3/4	171	4-3/4	121	6-1/4	159	5-1/2	140
2	50	5-3/16	132	4-9/16	116	7-1/2	190	4-3/4	121	7-1/2	190	6-1/4	159

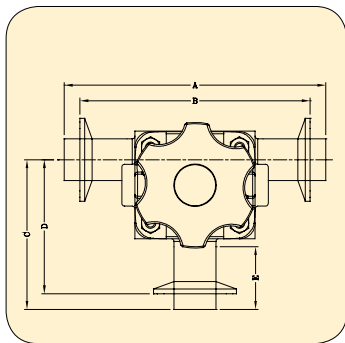
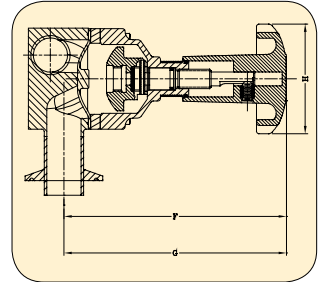

Run Tubing Size

Branch Valve Size	1/2	3/4	1	1-1/2	2	2-1/2	3	4
	1/2	T-Pattern	T-Pattern	T-Pattern	T-Pattern	T-Pattern	T-Pattern	T-Pattern
3/4		T-Pattern	T-Pattern	T-Pattern	T-Pattern	T-Pattern	T-Pattern	T-Pattern
1			T-Pattern	T-Pattern	T-Pattern	T-Pattern	T-Pattern	T-Pattern
1-1/2				T-Pattern	T-Pattern	T-Pattern	T-Pattern	T-Pattern
2					T-Pattern	T-Pattern	T-Pattern	T-Pattern
2-1/2						T-Pattern	T-Pattern	T-Pattern
3							T-Pattern	T-Pattern
4								T-Pattern

Zero DL™ Tank Bottom Dimensions

Size	A		C	D		E		F		G		
	INCHES	MM		INCHES	MM	INCHES	MM	INCHES	MM	INCHES	MM	
1/4	8	As Specified	2-9/16	65	1-9/16	40	1/2	13	4	102	3	76
3/8	10	As Specified	2-3/4	70	1-9/16	40	1/2	13	4	102	3	76
1/2	15	As Specified	3-1/2	89	3	76	1/2	13	4	102	3	76
3/4	20	As Specified	3-3/4	95	3	76	1/2	13	4-1/4	108	3	76
1	25	As Specified	4-5/16	110	3	76	1/2	13	4-1/2	114	4-1/2	114
1-1/2	40	As Specified	6-3/4	171	4-3/4	121	1/2	13	6-5/8	168	5-1/2	140
2	50	As Specified	7-1/2	190	4-3/4	121	1/2	13	7-1/8	181	7	178
3	75	AS Specified	10-1/2	267	8	203	3/4	19	11-5/8	295	10	254

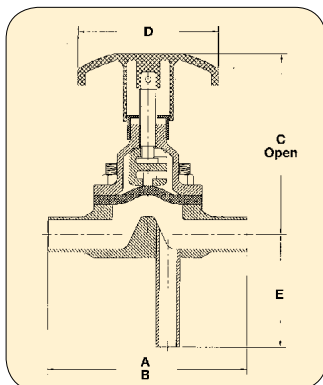
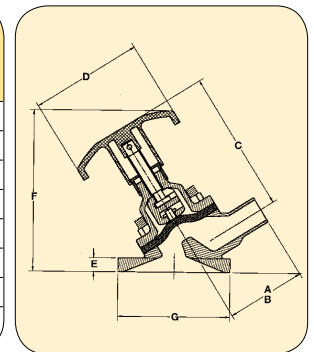

L-Pattern Dimensions

Size	A		B		C		D		E		
	INCHES	MM	INCHES	MM	INCHES	MM	INCHES	MM	INCHES	MM	
1/2	15	4-1/4	108	3-1/2	89	3-1/2	89	3	76	2-1/2	64
3/4	20	4-5/8	118	4	102	3-3/4	95	3	76	2-5/8	67
1	25	5	127	4-1/2	114	4-5/16	110	3	76	2-13/16	71
1-1/2	40	6-1/4	159	5-1/2	140	6-3/4	171	4-3/4	121	3-1/4	83
2	50	7-1/2	190	6-1/4	159	7-1/2	190	4-3/4	121	3-1/2	89
3	75	10	254	8-3/4	222	10-1/2	267	8	203	4	102

Zero DL[®] Point of Use Valve



The **Zero DL[®] Point-of-Use Valve** utilizes the T-pattern design to promote efficient installation when used on clean water loops. The main valve body is machined from a solid block of 316L stainless steel. It's design improves drainability and eliminates deadlegs within a processing system. Available in valve sizes 1/2" to 4" with tubing run sizes through 6" in clamp , buttweld ends, and other specialty connections.

- Integral sample valves, and downstream purge ports available upon request.

Sterile Access Valve

The Sterile Access Valve assembly provides access to the horizontal valve body at the lowest cross sectional point. The access port can be used for sampling, steam sterilization, purging or condensate drainage. Ports are furnished with buttweld tube ends, clamp ends, or the utilization of a secondary valve.



Top-Flo[®] Divert Valve



Top Line also offers a line of multi-ported divert valves that are very popular in process applications where space considerations are critical. These valves are compact and will significantly reduce the piping requirements and number of connections associated with more complex designs.

Top-Flo[®] Divert Valves are available in two-way through eight-way configurations and can be supplied with actuated or manual bonnets. Bodies that make up the valve are machined from 316L stainless steel. Other alloys such as Hastelloy or AL6XN can be provided upon request. These valves are supplied with a clamp or weld end connection in sizes ranging from 1/4" through 4". This patented design can be used to divert flow or as a mixing valve. The inlet flow passage with the divided flow prevents abrupt directional change and fluid impact, minimizing cell deterioration. **The Top-Flo[®] 2-Way Divert Valve** will drain in either the horizontal or vertical position. All other combinations will fully drain in the vertical position.

Features and Benefits

- Manufactured from 316L stainless steel or other alloys.
- Mill test summaries furnished with every order.
- Wide variety of inlet and outlet tubing configurations and polish combinations are available.
- Design eliminates deadleg inherent in typical mixing or diverting applications.
- Available with actuated or manual bonnets.
- Significantly reduces overall spacing requirements.

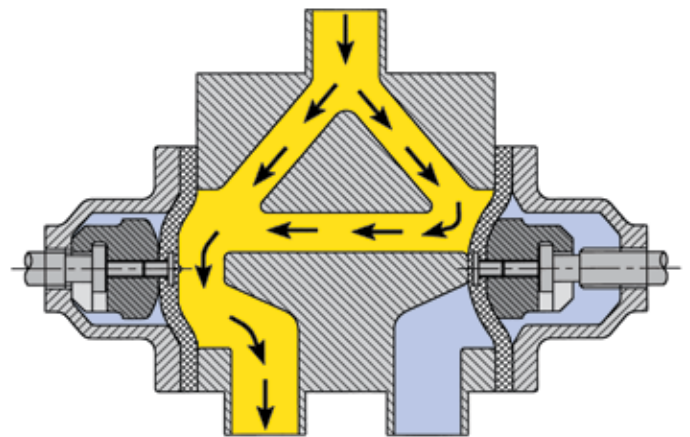

The flow pattern on the closed side of the valve will allow for a continuous flow to the open side providing zero deadleg.

Actuation

Compact Actuator (SRS 50)

The **Top Line** compact pneumatic actuator is highly suited for today's modern space-saving environment within the high purity industry. Simplicity of design and robust structure ensures long service life and economical operation. Molded from a high performance polymer to withstand the rigors of cleaning and sterilization temperatures, this light-weight actuator has no corrosive components exposed to atmosphere. All internal and external components are corrosion resistant. In-line retrofitting is easily achieved without the use of special tooling. Many accessory options are offered to suit any control application including proximity and mechanical switches, positioners, and limit stops. Available in size ranging from 1/4" to 4".

Features and Benefits

- **Compact / Lightweight**

Space-saving. Ease of installation and maintenance and mounts without additional support.

- **Fully Sealed**

Prevents contaminants from entering the housing while minimizing the risk of leakage between chambers.

- **Durability**

Longer life expectancy. Higher cycle performance.

- **Air Connections**

Parallel to piping system for ease and positive installation.

- **Visual Indicator**

Identifies valve position.

- **Material of construction**

Molded from a high performance polymer capable of withstanding elevated temperatures common to cleaning protocols.

- **Accessories**

Available to suit any control application.

TL Actuator (SRS 20, 30, 40)

Designed to be economical, compact, light-weight and durable, featuring a rugged cast iron housing and steel diaphragm plates, Top Line actuators are ideally suited for automatic and remote control of sanitary weir type diaphragm valves.

Features and Benefits

Cast Iron Housing - Tough and protective, permits the installation of all standard accessories - travel stops, manual overrides, limit switches, positioners, filter regulators, speed controllers and solenoid valves. Available with optional white epoxy coating.

- **Steel Diaphragm Plates**

Superior performance in high pressure service.

- **Positive Stop**

Provides added safety when manual override is used.

- **Actuator Diaphragm**

Flexible for repeated cycling.

- **Bonnet**

Compact and integral to the actuator providing better alignment to insure exceptional cycling. This unique design allows for easy field installation and adapts to most diaphragm valve bodies.

- **Stem Guide**

Unique seal arrangement prevents lateral stem movement.

- **Position Indicator**

Indicates valve position optional.

- **Spring Adjustment**

Spring tension can be externally adjusted to provide optimum performance.

Topline actuators provide the perfect solution to any valve automation requirement. Top Line actuators are compact, lightweight and possess excellent throttling capabilities.



Actuation Data (SRS 50)

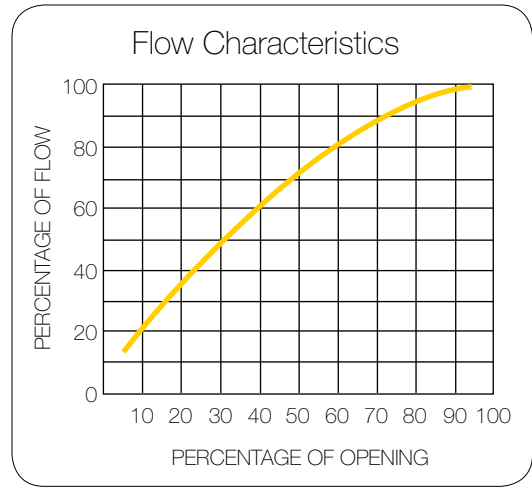
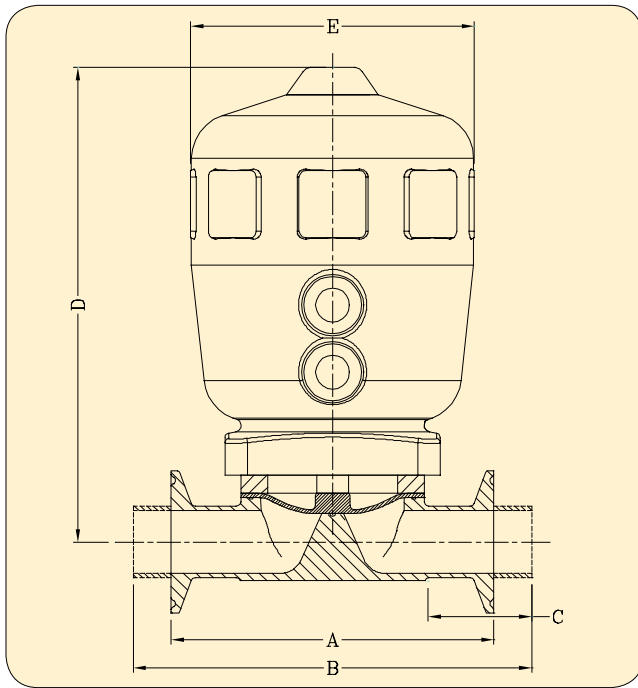

Bio-Pro® Forged Automated Valve Dimensions Elastomer Diaphragm Type

Size	A Clamp End	B Od Tube End	C Weld Tangent	D Center To Top	E Act Ø	F Drain Angle
1/2"	3.50	4.88	1.50	4.60	2.50	30°
3/4"	4.00	5.31	1.50	5.70	3.15	25°
1"	4.50	5.56	1.50	6.10	3.15	28°
1 1/2"	5.50	6.63	1.50	9.10	5.00	20°
2"	6.25	7.50	1.63	9.60	5.00	20°
2 1/2"	7.63	10.00	1.88	15.04	8.31	18°
3"	8.75	10.00	1.88	15.71	8.31	20°
4"	11.50	12.84	2.00	16.11	10.28	15°
6"*	13.40	18.00	3.00	37.00	18.13	15°

* Machined From 316L Wrought Bar

Bio-Pro® Forged Automated Valve Dimensions TFM Faced Diaphragm Type

Size	A Clamp End	B Od Tube End	C Weld Tangent	D Center To Top	E Act Ø	F Drain Angle
1/2"	3.50	4.88	1.50	5.30	3.15	30°
3/4"	4.00	5.31	1.50	6.80	4.00	25°
1"	4.50	5.56	1.50	6.90	4.00	28°
1 1/2"	5.50	6.63	1.50	10.70	6.00	20°
2"	6.25	7.50	1.63	10.90	6.00	20°
2 1/2"	7.63	10.00	1.88	15.27	10.28	18°
3"	8.75	10.00	1.88	15.51	10.28	20°
4"	11.50	12.84	2.00	16.11	10.28	15°
6"*	13.40	18.00	3.00	7.00	18.13	15°

* Machined From 316L Wrought Bar

Actuation Data (SRS 50)

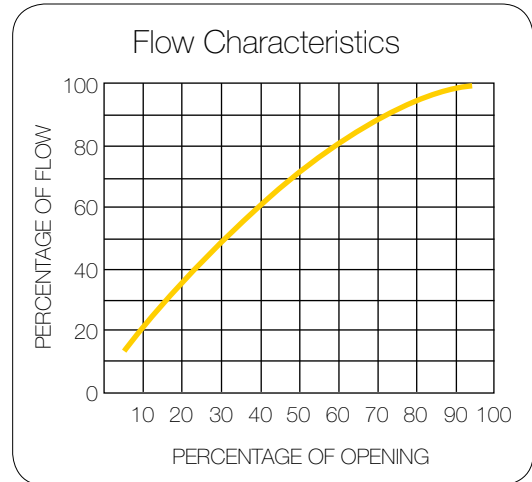
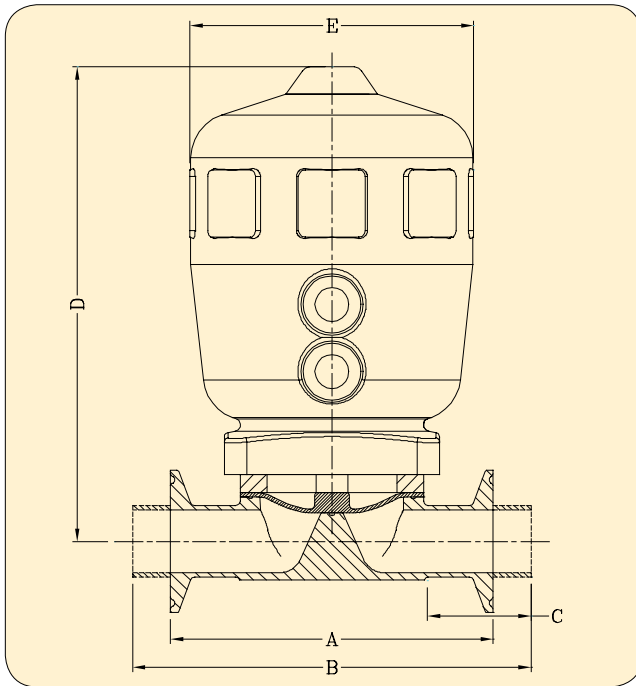

Bio-Pro® Cast Automated Valve Dimensions Elastomer Diaphragm Type

Size	A Clamp End	B Od Tube End	C Weld Tangent	D Center To Top	E Act Ø	F Drain Angle
1/2"						
3/4"						
1"						
1 1/2"	5.50	6.25	1.31	9.10	5.00	20°
2"	6.25	7.50	1.59	9.60	5.00	20°
2 1/2"						
3"	8.75	10.00	1.75	10.00	8.00	20°
4"	11.50	12.50	1.63	13.63	10.00	15°
6"						

Bio-Pro® Cast Automated Valve Dimensions TFM Faced Diaphragm Type

Size	A Clamp End	B Od Tube End	C Weld Tangent	D Center To Top	E Act Ø	F Drain Angle
1/2"						
3/4"						
1"						
1 1/2"	5.50	6.25	1.31	10.70	6.00	20°
2"	6.25	7.50	1.59	10.90	6.00	20°
2 1/2"						
3"	8.75	10.00	1.75	10.00	8.00	20°
4"	11.50	12.50	1.63	13.63	10.00	15°
6"						

Actuation Data (SRS 20, 30,40)

20 Series - Double acting:
Air to open/Air to close
40 Series Spring to open/Air to close

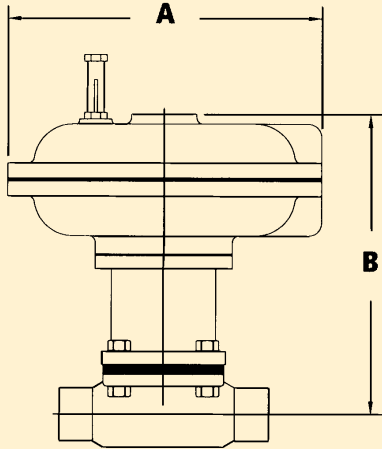

30 Series Air to open/Spring to close

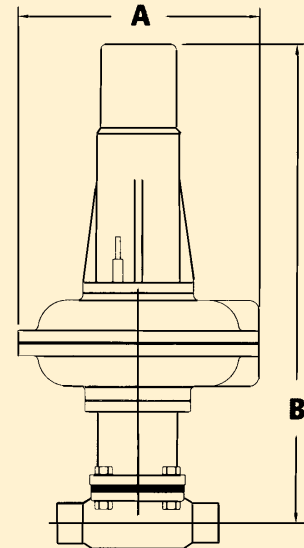

20 Series - Double Acting Actuators

Model	Dia. (A)	Center to Top (B)						
		1	1-1/2	2	2-1/2	3	4	6
	6	8-15/16	-	-	-	-	-	-
	7-3/4	9-7/8	9-9/16	11-1/8	-	-	-	-
21	9-1/2	-	10-7/16	12	11-11/16	11-13/16	-	-
	12-1/4	-	-	12-7/8	12-9/16	12-11/16	13-7/8	-
	14-7/8	-	-	-	-	-	14-1/2	17-15/16

40 Series - Spring To Open Actuators

Model	Dia. (A)	Center to Top (B)						
		1	1-1/2	2	2-1/2	3	4	6
	6	8-15/16	-	-	-	-	-	-
	7-3/4	9-7/8	9-9/16	11-1/8	-	-	-	-
47	9-1/2	-	10-7/16	12	11-11/16	11-13/16	-	-
	12-1/4	-	-	12-9/16	12-9/16	12-11/16	13-7/8	-
	14-7/8	-	-	-	-	-	14-1/2	17-15/16

30 Series - Spring Close Actuators

Model	Dia. (A)	Center to Top (B)						
		1	1-1/2	2	2-1/2	3	4	6
	6	18-15/16	-	-	-	-	-	-
	7-3/4	19-7/8	19-9/16	-	-	-	-	-
34	9-1/2	20-3/4	20-7/16	22	-	-	-	-
	12-1/4	-	-	22-7/8	27-7/16	27-9/16	30-7/8	-
	14-7/8	-	-	-	28-1/16	28-3/16	31-1/2	-
	18-1/8	-	-	-	-	-	-	49-9/16

Bonnet Assemblies

Top-Flo® manual bonnets offer many features that have been carefully designed with the user in mind. The new bonnet design takes into account environmental stresses such as cleanability, reliability, autoclave use, adjustment, and ease of maintenance.

Top-Flo® 304 stainless steel bonnets are produced using the investment casting process resulting in a complete durable and lightweight topworks. Stainless steel bonnets are electropolished externally providing a bright and sanitary exterior that also enhance its corrosion resistance. Ergonomically designed PPS thermoplastic handwheel and highly visible yellow indicator are standard on stainless steel bonnets sizes 1/2"-2". Bonnet sanitary internals are stainless steel and bronze as standard. Bonnet sizes 2 1/2" – 6" are electropolished 304 stainless steel bodies and handwheels with sanitary internals.

The **Top-Flo®** manual bonnet incorporates a simple mechanism to adjust diaphragm squeeze which greatly enhances diaphragm life span. The adjustable close stop incorporates a sliding shaft/set screw design for ease of setting with only simple tools needed. No handwheel removal or additional caps or gears to set or reinstall.

For applications where contamination is of concern, "09"

stainless bonnets are dual viton o-ring sealed as standard. Viton o-ring seals in the handwheel and stem areas prevent contamination from entering through or exiting from the bonnet in case of diaphragm failure and prevent washdown fluid ingress.

All bolts used with the style bonnet are fully encapsulated when installed without the use of additional plastic caps or plugs to eliminate external entrapment areas. When Top-Flo® new style bonnets are used on block style valves, acorn nuts compliment the fasteners to ensure no exposure to bolt threads.

Top-Flo® manual bonnets enjoy a full complimentary range of options including but not limited to limit or proximity switches for position indicating, pad-lockable hand wheel, mechanically polished exterior, stem extensions, and adjustable open stops.

Cast Iron Bonnets

For lesser applications or additional bottom line savings, cast iron bonnets and optional cast iron epoxy coated bonnets are available in sizes 2 1/2"-6". Sanitary internals, built-in travel stops, and highly visible position indicator are standard features.



Diaphragms

Top Line has understood for over 30 years that reliability is of the utmost importance on each product or service offered. Our customers demand it and we work very hard to make sure that it is provided on a continual basis. **Top-Flo®** diaphragms are no exception.

Top Line understands that the most important factor of diaphragm valve reliability is the diaphragm itself. To achieve optimum diaphragm performance, only the highest-grade specially engineered materials are used in our diaphragm production. Steam cycle testing is performed on all grades of Top Line diaphragms to ensure the best possible life span of the diaphragms. All diaphragms are produced and controlled in the United States and Canada under a compliant and registered ISO 9001-2000 Quality Management System (QMS).

Grade 2E Peroxide Cured EPDM

Certifications & Approvals

Top-Flo® Grade 2E diaphragms are fully compliant to FDA CFR Section (21) 177.2600 and have been fully tested and certified in accordance with U.S. Pharmacopoeia Class VI Section (87) in-vitro and Section (88) in-vivo biological reactivity tests by the accredited NAMSA.

Extractables & Production

Grade 2E EPDM compound has been developed to have the lowest extractable percentage and has been independently tested to be significantly less than commercial compounds and similar competitive products.

Top Line EPDM diaphragm compound is produced in just-in-time batches to meet tight diaphragm production and is stored for very short periods to ensure greater reliability of the mechanical properties of the diaphragm after production.

Diaphragm Materials And Temperature Range

Grade	Material	Temperature Range	
		Fahrenheit	Celsius
2E & BE	FDA/USP Black EPDM	-40° – 300°F	40° – 150°C
2V	FDA Black Viton®	0° – 350°F	-15° – 150°C
BK	Compact TFM/EPDM	0° – 300°F	-15° – 150°C
1KS	Bayonet Steam TFM/EPDM	0° – 350°F	-15° – 175°C
2KS	Threaded Steam TFM/EPDM	0° – 350°F	-15° – 175°C
1PS	Bayonet Steam TFM/Viton®	25° – 350°F	-4° – 175°C
2PS	Threaded Steam TFM/Viton®	25° – 350°F	-4° – 175°C



Grade 1KS & 2KS TFM/EPDM

Certifications & Approvals

Top-Flo® Grade 1KS & 2KS diaphragms are fully compliant to FDA CFR Section (21) 177.2600 and have been fully tested and certified in accordance with U.S. Pharmacopoeia Class VI Section (87) in-vitro and Section (88) in-vivo biological reactivity tests by the accredited NAMSA.

Production

Top Line Grade 1KS & 2KS diaphragms are manufactured utilizing a proprietary unique high pressure molding technique that ensures better density and is virtually non-permeable. More importantly, this process significantly increases the cycle life of the diaphragm under harsh conditions.

Traceability

All Top Line diaphragms are fully traceable to a specific batch of the molded compound. Test certificates and compound properties for each specific batch are recorded and maintained within the QA system. Diaphragms are physically identified with the date of manufacture and the compound identification code.

Each **Top-Flo®** diaphragm valve is supplied with your choice of elastomer or TFM/elastomer backed materials. Diaphragms are completely compliant with the most recent FDA codes, USP standards and are fully traceable.

Elastomer diaphragms are molded in the open position, while TFM faced diaphragms are molded in the closed position. All elastomer type diaphragms are attached to the bonnet or actuator compressor via threaded stud. Top Line standard TFM faced diaphragms are attached by a bayonet type fixture that eliminates point loading, thus providing constant diaphragm compression across the weir resulting in a more uniform and reliable seal. Optional TFM faced diaphragms can be supplied with a threaded type fixture for interchangeability with other major manufacturers.

Engineering

Sterile L-Pattern Configurations

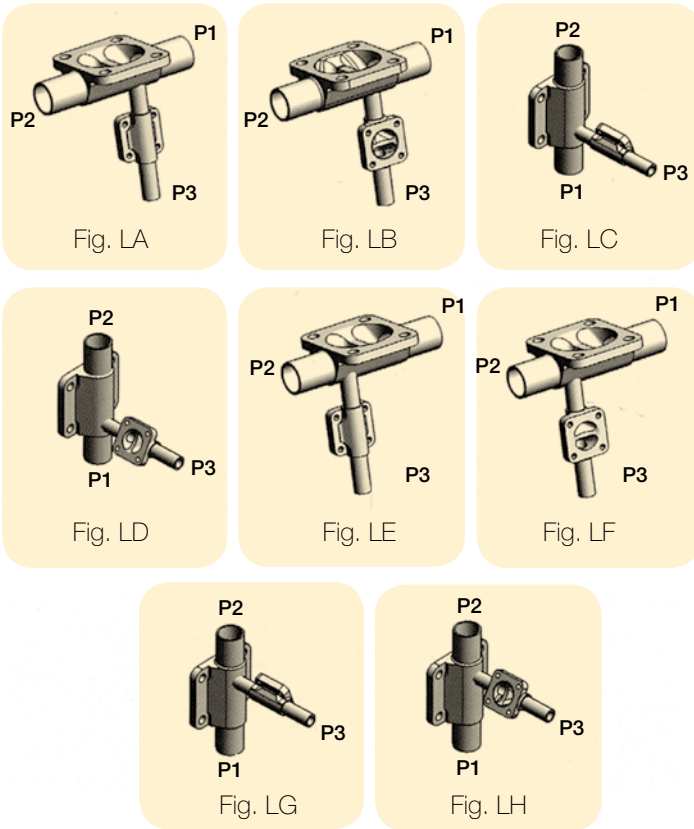

Sterile Access Configurations

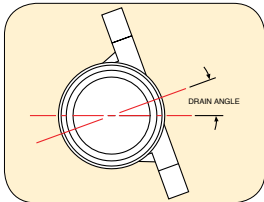
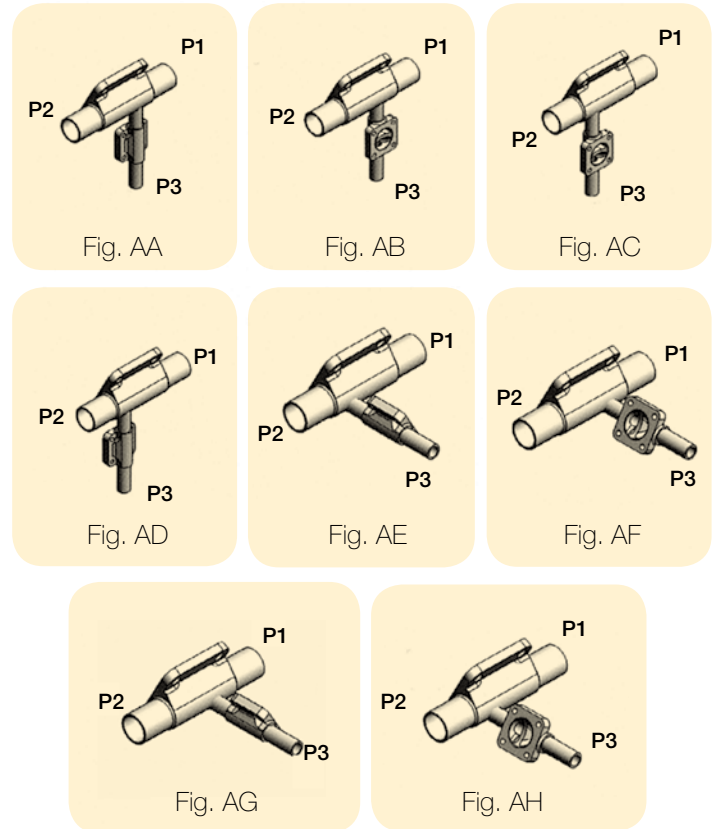

Drain Angle

Size	1/4"	3/8"	1/2"	3/4"	1"	1 1/2"	2"	2 1/2"	3"	4"	6"
Bio-Flo®II	35°	30°	25°	-	-	-	-	-	-	-	-
Bio-Pro®	-	-	30°	25°	28°	20°	20°	18°	20°	15°	15°

Flow Data - Forged & Cast 2-Way Valves

CV Values USGPM At One PSI

Size % Open	Bio-Flo® II			Bio-Pro®							
	1/4"	3/8"	1/2"	1/2"	3/4"	1"	1 1/2"	2"	2 1/2"	3"	4"
12.5	0.47	0.49	0.50	0.52	1.75	2.60	9.80	13.50	29.00	38.30	49.00
25	0.61	0.68	0.71	0.87	3.28	5.65	18.60	35.00	54.00	68.90	12.00
50	0.67	1.56	1.66	1.87	5.47	12.50	35.50	54.30	77.60	136.40	270.00
75	0.69	1.84	2.23	2.48	6.78	16.70	44.60	68.00	88.60	167.00	376.00
100	0.78	1.90	2.45	3.32	7.60	18.70	46.80	71.00	91.90	177.60	404.00

KV Values Cubic Meter per Hour per At One Bar

Size % Open	Bio-Flo® II			Bio-Pro®							
	1/4"	3/8"	1/2"	1/2"	3/4"	1"	1 1/2"	2"	2 1/2"	3"	4"
12.5	0.41	0.42	0.43	0.45	1.51	2.25	8.48	11.68	25.09	33.13	42.39
25	0.53	0.59	0.61	0.75	2.84	4.89	16.09	30.28	46.71	59.60	96.88
50	0.58	1.35	1.44	1.62	4.73	10.81	30.71	46.97	67.12	117.99	233.55
75	0.60	1.59	1.93	2.15	5.86	14.45	38.58	58.82	76.64	144.46	325.24
100	0.67	1.64	2.12	2.87	6.57	16.18	40.48	61.42	79.49	153.62	349.46

Engineering

One of the effective methods known for removal of minor surface abnormalities and to improve the finish on a product is the electropolish process.

Electropolishing reduces minor scratches and other surface imperfections by removing metal from the product. The process creates a smoother and more level surface finish which cannot be achieved by mechanical polishing alone. The end result is the reduction of such imperfections from the product thus making them easier to be cleaned and lessens the potential for corrosion or contamination to occur.

Top Line is aware and conforms to the higher standards the pharmaceutical and bio-processing industries demand. Our commitment to customers is that we are able to provide the required finishes on products consistently by means of our in-house EP facility. This arrangement allows us to better control the quality, service, and integrity of the finished product.

Benefits of the electropolishing process:

- Peaks and scratched surfaces caused by mechanical polishing are greatly reduced.
- The passivation process provides greater corrosion resistance.
- Any defective welds or pitting on the surface of the product will be revealed.
- The overall appearance of the product can be enhanced.
- Cleaning and sterilization of the product is made easier.
- Assists removal of surface entrapped contaminants.

Surface finish in the pharmaceutical and bio-processing industries is normally measured in (Ra) or roughness average, expressed in terms of microinch or micrometer (micron) values. Top Line uses inspection equipment, such as profilometers and boroscopes to accurately evaluate the surface finish.

Identifies a specific maximum roughness

MECHANICAL POLISH				
	Micron	Microinch (Ra)	Grit No.	ASME BPE
Bio-Pro® Bio-Flo® & Specialty Valves	0.75	30-35	150	SFV3
	0.62	25	180	SFV2
	0.50	20	240	SFV1
Bio-Pro Cast®	0.75	30-35	150	SFV3
	0.62	25	180	SFV2

MECHANICAL AND ELECTROPOLISH				
	Micron	Microinch (Ra)	Grit No.	ASME BPE
Bio-Pro® Bio-Flo® & Specialty Valves	0.62	25	180	SFV6
	0.50	20	240	SFV5
	0.37	15	320	SFV4

Ordering Information Top Line Sanitary Diaphragm Valves - figure number chart

Body Type	End Connection	Material / Finish	Bonnet	Diaphragm
6. Weir Bio-Flo®	4. Clamp End Std	L3. 20Ra	02. Cast Iron Indicating	2E. Black EPDM
7. Weir Forged	5. Clamp End Pipe	L4. 20Ra EP	09. Stainless / PPS Handwheel	2V. Blackviton
8. Weir Cast	6. Special Clamp	L5. 15Ra	10. Stainless / SS Handwheel	1KS. Bayonet Steam TFM/EPDM
9. Tank Bottom	7. 14 Gaugetube End	L6. 15Ra EP	13. Epoxy Coated Bonnet (Gray)	2KS. Threaded Steam TFM/EPDM
2. L Pattern	8. 16 Gaugetube End	L7. 10Ra	18A. Bio-Flo® Sealed Bonnet	1PS. Bayonet Steam TFM/Viton®
4. T-Pa Tern Valve	9. 18 Gaugetube End	L8. 10Ra EP	20. Double Acting Actuator - MBS	2PS. Threaded Steam TFM/VITON®
0. Divertvalve	0. 20 Gaugetube End	L9. Special Finish	30. Spring/Close Actuator - MBS	BE. Black EPDM - Bio-Flo®
A. Access	X. Specials		40. Spring/Open Actuator - MBS	BK. TFM/EPDM - Bio-Flo®
S. Specialty Valve	C. Combination		51. D.A. Compact Actuator BCS	
U. Point Of Use			54. N.C. Compact Actuator BCS	
J. Jacketed (Forging Only)			57. N.O. Compact Actuator BCS	

EXAMPLE:

316 L Forged Body Valve	Clamp Ends	20Ra Finish SFV5	Sealed Stainless, Bonnet W/PPS Handwheel	TFM/ EPDM
7	4	L4	-09	1KS



. . . the source for
all your product needs
in the process industries

Contact your Top Line Representative for Assistance

Office: P.O. Box 264 · Bradford, PA 16701

Plant: 21 Valley Hunt Drive · Lewis Run, PA 16738

800-458-6095

814-362-4626

Fax: 814-362-4453

Top Line has been supplying high quality stainless steel products to the dairy, food, beverage, pharmaceutical and other process industries for over forty years. Our commitment to fine craftsmanship, responsible service and realistic pricing has led to our company's successive years of growth.

Top Line specializes in stainless steel materials – types 304, 316, and “L grades”. Our modern, well equipped manufacturing facilities are staffed by skilled and dedicated craftsmen. Consistently meeting important tolerances and finish specifications is of primary concern to us. Before any products leave our plant they are subjected to rigid quality assurance checks.

Top Line should always be considered your first choice for both standard and custom fabricated stainless steel products.

Limited Warranty

Top Line Process Equipment Company products are warranted to be free of defects in material or workmanship for a period of one year from date of shipment. Warranty covers those Top Line products used in an approved installation and maintained in strict accordance with recognized standard industry practice. If, after properly authorized return, Top Line determines that products are defective, Top Line may at its option, repair or replace such defective products.

Top Line shall not be liable for consequential, indirect or incidental damages. The above warranty is in lieu of all other warranties, expressed or implied.